

Direction of the light beam

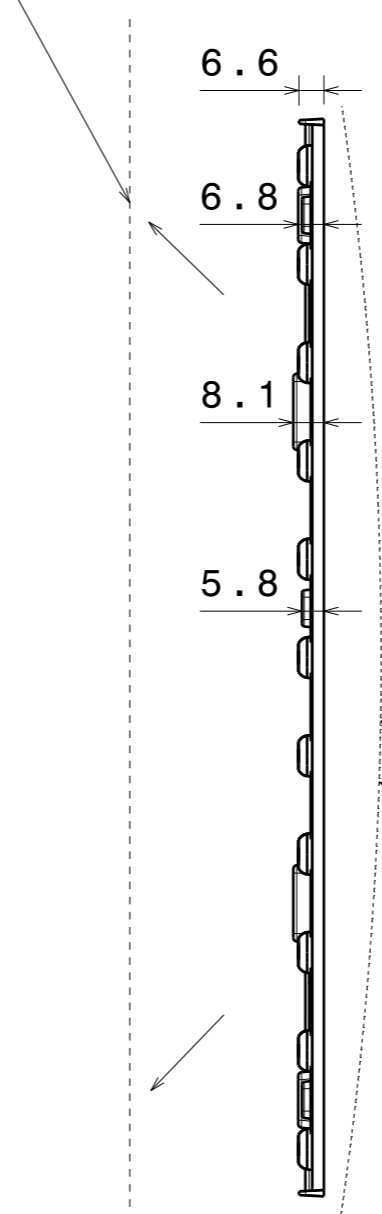

Section view B-B
Scale: 1:1

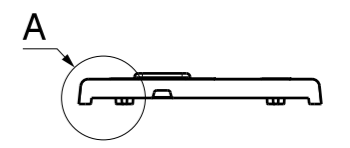
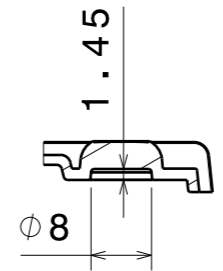

Detail A
Scale: 1:1

Allowed bending direction

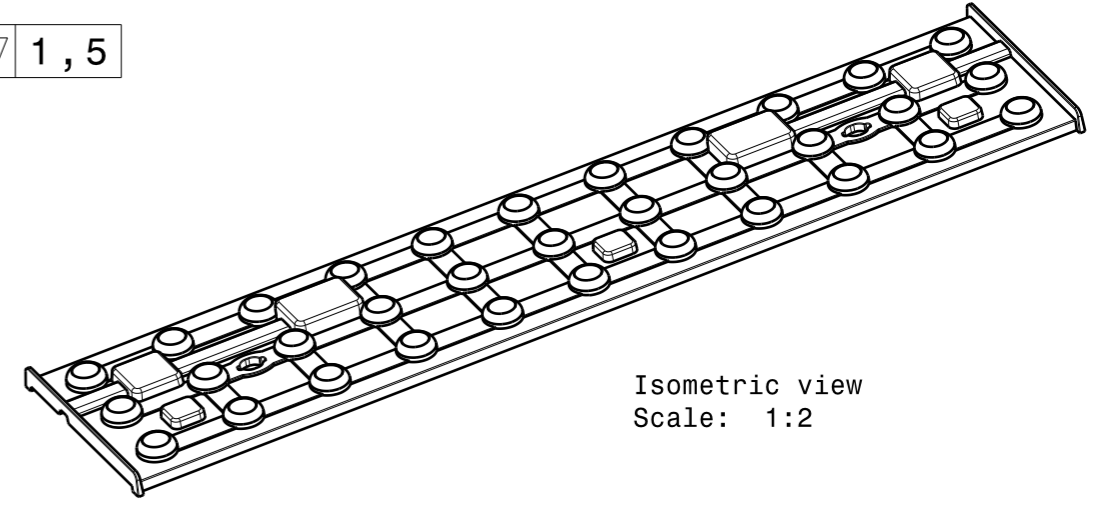
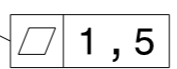

Isometric view
Scale: 1:2

Direction of the light beam

Notes

- PCB or heatsink level.
- LED location
- Ensure LED fitting from a product specific 3D model available from www.ledil.com
- See installation details page 2.

INDEX	PART	TYPE	MATERIAL	COLOR / COATING
1	F16008_Florence2-Z60	LENS	PMMA	CLEAR

MECHANICAL DRAWING		LEDiL
PRODUCT FLORENCE2 - Z60		
Plastic moulding general tolerances according to DIN 16901-130 and applies if not otherwise shown in the drawing. Silicone moulding general tolerances according to ISO 3302-1 Class M3 and applies if not otherwise shown in the drawing.	FIRST ANGLE PROJECTION: 	This drawing is the property of LEDiL Oy. It may not be copied or otherwise distributed without prior written permission from LEDiL Oy.
SCALE 1:2	WEIGHT -	A3 SHEET 1/2

PCB & LENS fixing: Recommended screw M4 for fixing

Use washer with screw if possible

Lens: Florence2-Z60

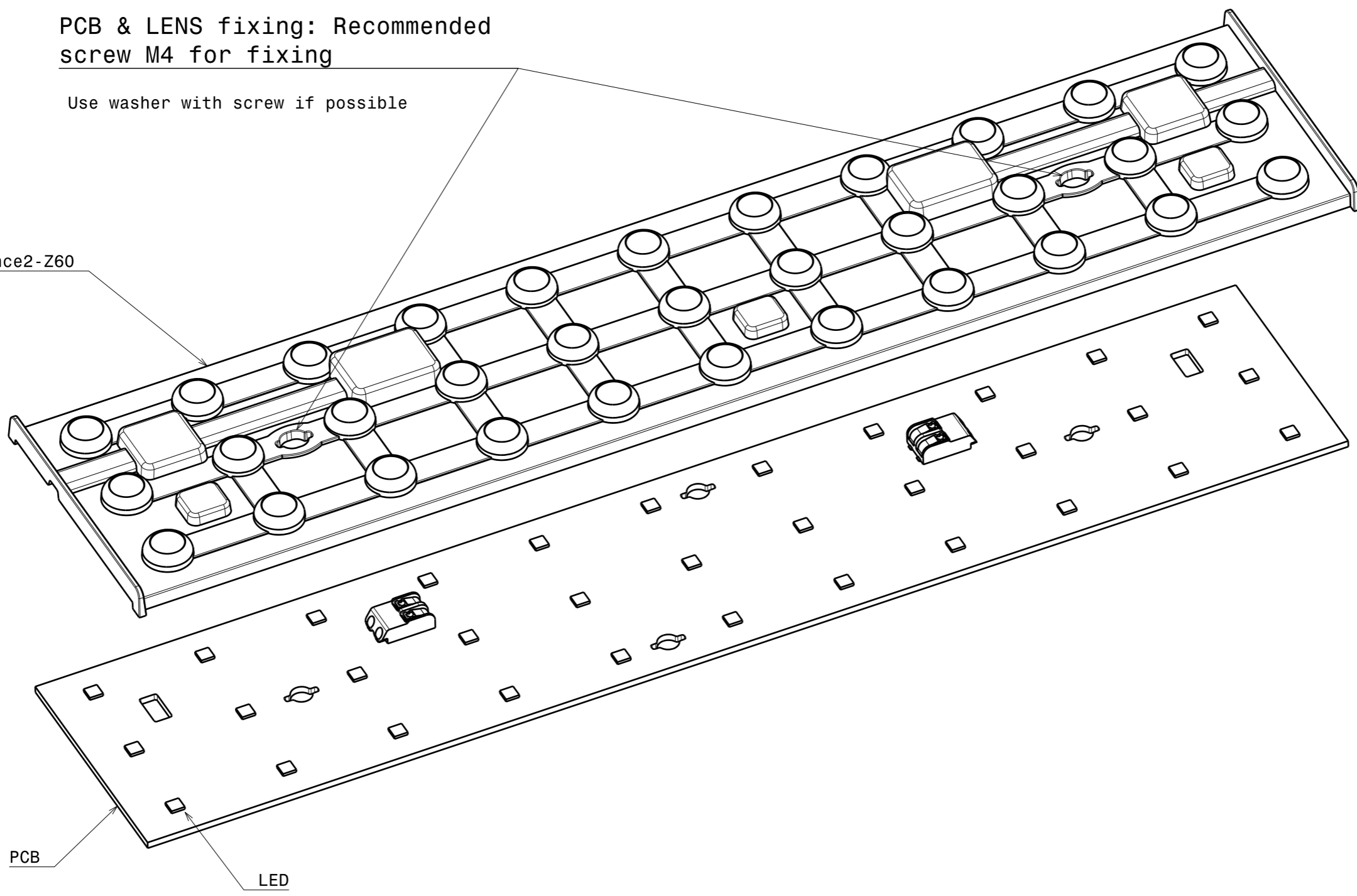

Notes

For more details about installation please see LEDIL Installation Guide on www.ledil.com

MECHANICAL DRAWING		LEDiL
PRODUCT	FLORENCE2 - Z60	
Plastic moulding general tolerances according to DIN 16901-130 and applies if not otherwise shown in the drawing. Silicone moulding general tolerances according to ISO 3302-1 Class M3 and applies if not otherwise shown in the drawing.	FIRST ANGLE PROJECTION: 	This drawing is the property of LEDiL Oy. It may not be copied or otherwise distributed without prior written permission from LEDiL Oy.
SCALE 1:1	WEIGHT -	