

CP19040_ AMY-70-WW-C2
 CP19114_ AMY-70-WW-C2-WHT
 CP18875_ AMY-70-WW-C2-PC
 CP19394_ AMY-70-WW-C2-WHT-PC

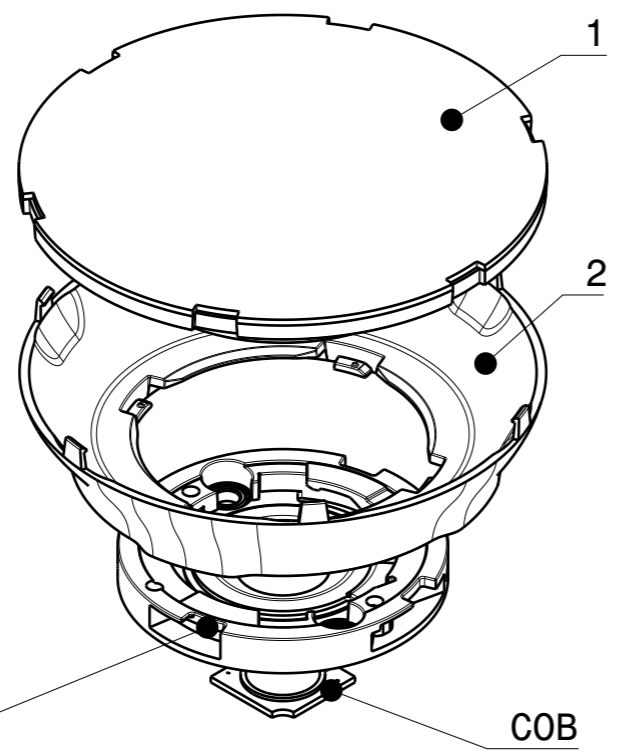
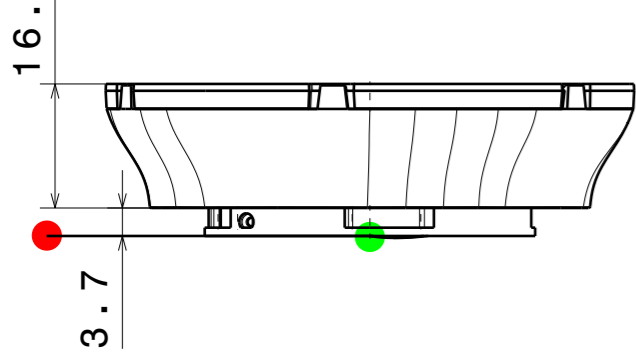

HEKLA
Connector

COB

CP19103_ AMY-70-WW-B2
 CP19118_ AMY-70-WW-B2-WHT
 CP18882_ AMY-70-WW-B2-PC
 CP19401_ AMY-70-WW-B2-WHT-PC

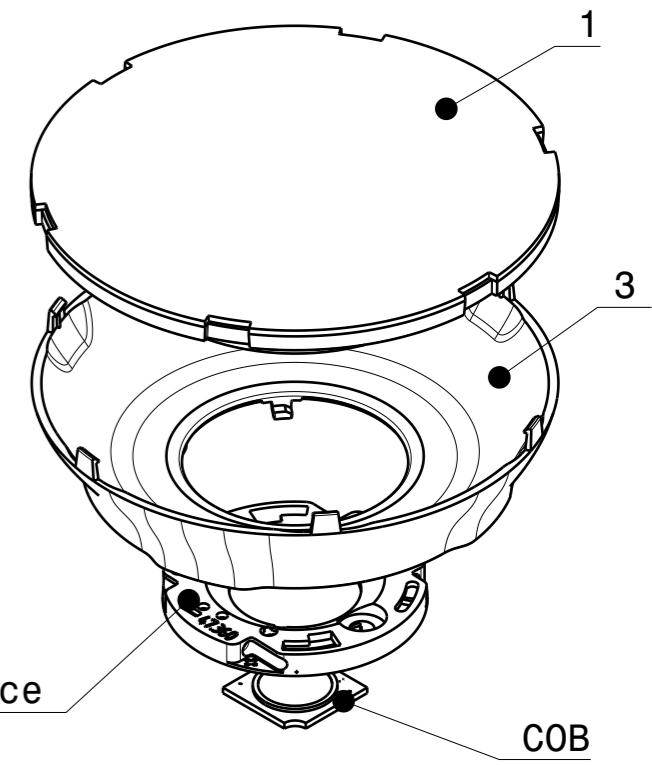
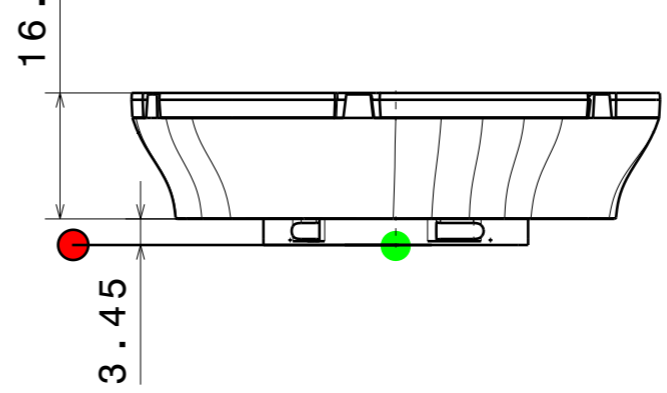

Connector
BJB / B+W 35mm-interface

COB

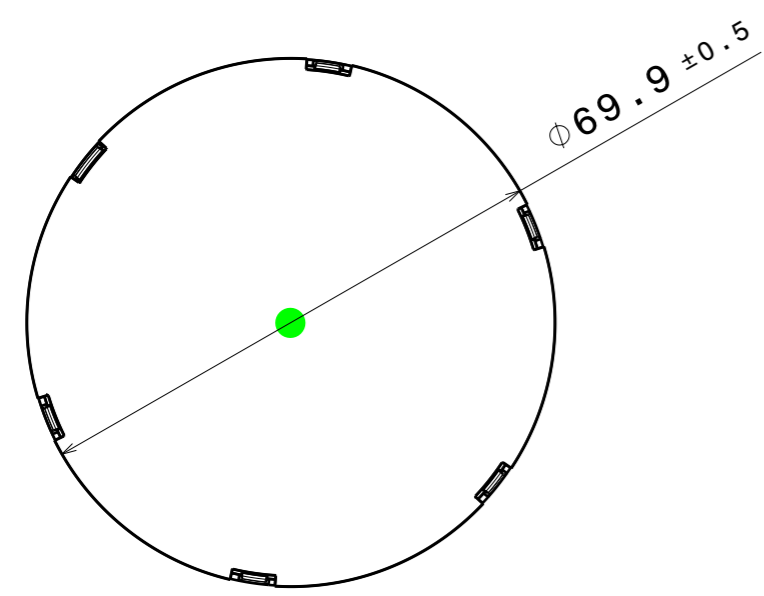

Top view
Scale: 1:1

INDEX	PART	TYPE	QTY	MATERIAL	COLOUR/COATING	ASSEMBLY CODES
1	AMY-70-WW	LENS	1			
	C17779_ AMY-70-WW			PMMA	CLEAR	
	C18868_ AMY-70-WW-PC			PC	CLEAR	
2	HOLDER C	HOLDER	1			
	C19021_ AMY-70-HLD2-C			PC	BLACK	CP19040_ AMY-70-WW-C2 CP18875_ AMY-70-WW-C2-PC
	C19023_ AMY-70-HLD2-C-WHT			PC	WHITE	CP19114_ AMY-70-WW-C2-WHT CP19394_ AMY-70-WW-C2-WHT-PC
3	HOLDER B					
	C19022_ AMY-70-HLD2-B			PC	BLACK	CP19103_ AMY-70-WW-B2 CP18882_ AMY-70-WW-B2-PC
	C19024_ AMY-70-HLD2-B-WHT			PC	WHITE	CP19118_ AMY-70-WW-B2-WHT CP19401_ AMY-70-WW-B2-WHT-PC

MECHANICAL DRAWING

PRODUCT
AMY-70-WW

Plastic moulding general tolerances according to DIN 16901-130 and applies if not otherwise shown in the drawing.
 Silicone moulding general tolerances according to ISO 3302-1 Class M3 and applies if not otherwise shown in the drawing.

FIRST ANGLE PROJECTION:

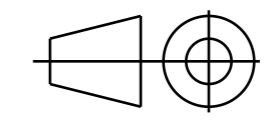

SCALE 1:1

WEIGHT -

LEDiL

This drawing is the property of LEDiL Oy. It may not be copied or otherwise distributed without prior written permission from LEDiL Oy.

A3 SHEET 1/1

Notes

●	PCB or heatsink level.
●	LED location
	Ensure LED fitting from a product specific 3D model available from www.ledil.com
	For more details about installation please see LEDiL Installation Guide on www.ledil.com

H G F E D C B A

4

4

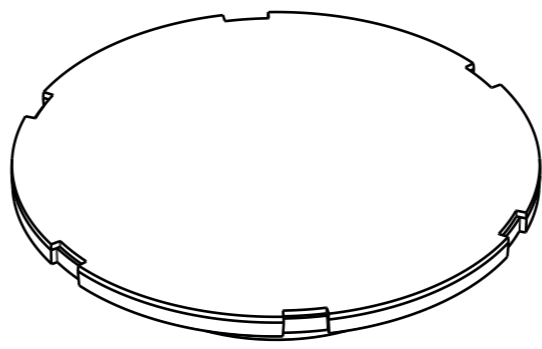
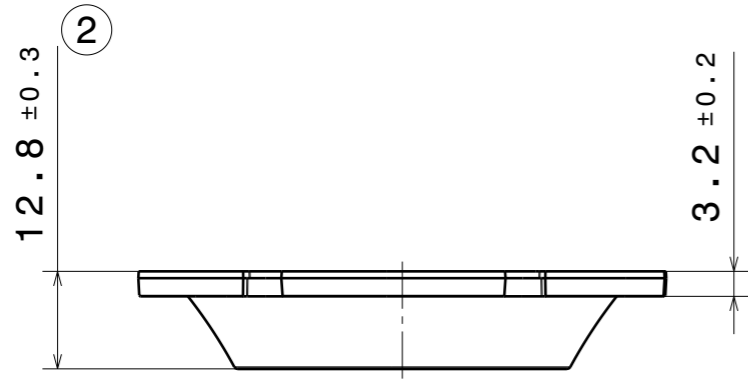

3

3

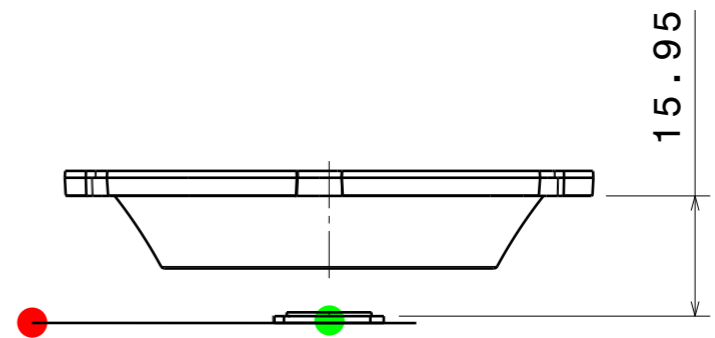
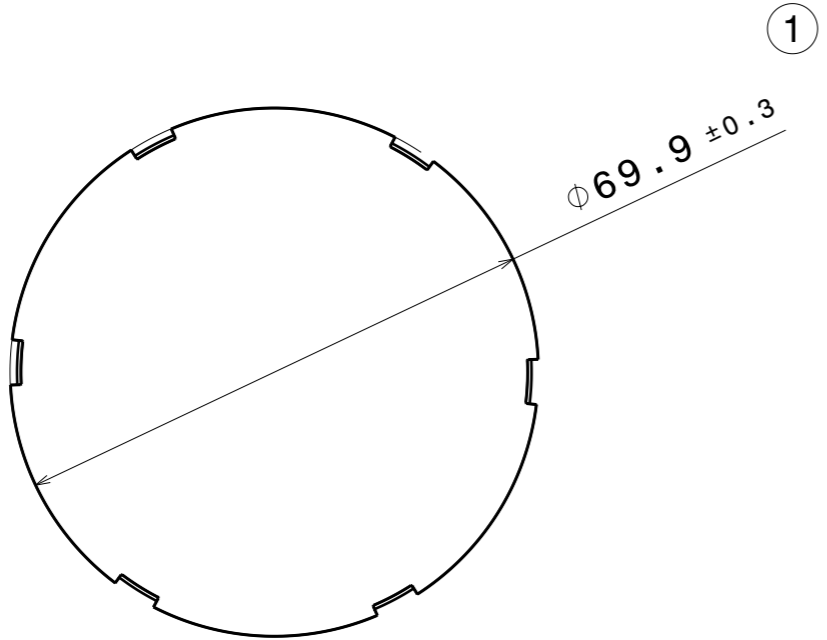

2

2

PART	TYPE	MATERIAL	COLOR / COATING
C17779_AMY-70-WW	LENS	PMMA	CLEAR
C18868_AMY-70-WW-PC	LENS	PC	CLEAR

MECHANICAL DRAWING

PRODUCT **AMY-70-WW**



Plastic moulding general tolerances according to DIN 16901-130 and applies if not otherwise shown in the drawing. Silicone moulding general tolerances according to ISO 3302-1 Class M3 and applies if not otherwise shown in the drawing.

FIRST ANGLE PROJECTION:

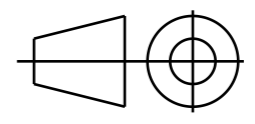

This drawing is the property of LEDiL Oy. It may not be copied or otherwise distributed without prior written permission from LEDiL Oy.

SCALE 1:1

WEIGHT -

A3 SHEET 1/1

1

1

Notes

	PCB or heatsink level.
	LED location
	Ensure LED fitting from a product specific 3D model available from www.ledil.com
	For more details about installation please see LEDiL Installation Guide on www.ledil.com

H G F E D C B A